



WELCOME

Henderson Drive Wildlife Eco-Passage
PUBLIC INFORMATION CENTRE

Your comments are encouraged and appreciated, as this will provide us an opportunity to address project issues and concerns.



STUDY PURPOSE / PROBLEM DEFINITION



Henderson Drive Wildlife Eco-Passage

The segment of Henderson Drive between McClenny Drive and Watts Meadow has been identified as a hotspot for wildlife collisions. Of particular concern, are roadside collisions associated with local turtle species. To minimize wildlife injuries and fatalities linked to roadway collisions, the Town has retained Aquafor Beech Limited to design a safe and efficient wildlife eco-passage system.

The proposed design will facilitate the safe movement of wildlife across Henderson Drive and reduce roadside wildlife collisions, while also helping to improve drainage out of Salamander Pond. These improvements will be realized by replacing the existing degraded culverts that cross underneath Henderson Drive with a new upgraded structure.

PUBLIC INFORMATION CENTRE PURPOSE



This Public Information Centre (PIC) is designed to:

- Present information on existing conditions
- Present the detailed design solution
- Delineate impacts to vegetation and private property



To gain community input on:

- Existing conditions information
- The detailed design solution
- Planned site restoration works
- Concerns related to the proposed works

PROJECT DEVELOPMENT



Henderson Drive Wildlife Eco-Passage

- The Lake Simcoe Region Conservation Authority (LSRCA) recently identified the section of Henderson Drive between McClenny Drive and Watts Meadow within the Town of Aurora as a wildlife mortality hotspot.
- Local residents have also been actively monitoring turtle activity in the study area for several years, and have documented a number of roadside fatalities associated with turtles crossing Henderson Drive when using the grassed boulevards on the north and south side of the road for nesting purposes.
- The existing culverts underneath Henderson Drive, that drain Salamander Pond (located within the Case Woodlot), have also been observed to be in a deteriorated condition, exhibiting signs of structural degradation and excess sediment accumulation.
- The retaining wall and guard rails on the North side of the street are also starting to show signs of failure, and should be replaced to ensure long-term protection of the roadway and boulevard features, and to also mitigate risks to public health & safety.
- This project is being undertaken to provide safe passage for turtles and other wildlife species across Henderson Drive; replace degraded infrastructure; and provide protection to the roadway from flood and erosion hazards.

STUDY AREA

The study area is situated along Henderson Drive between McClenny Drive and Watts Meadow. There is an existing twin barrel corrugated steel pipe (CSP) culvert in the center of the study area that provides drainage from Salamander Pond northward towards Lake Simcoe.

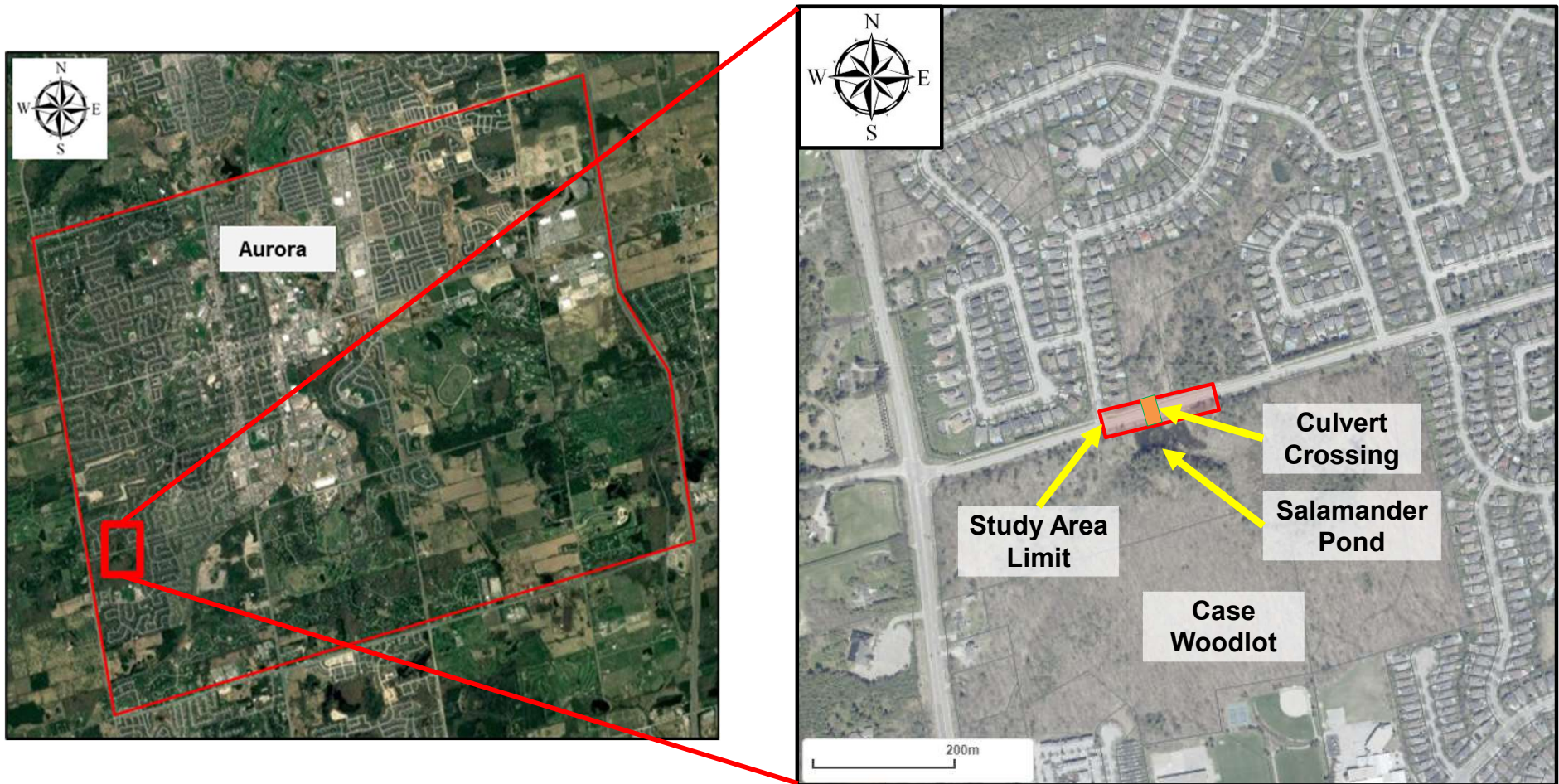

EXISTING CONDITIONS

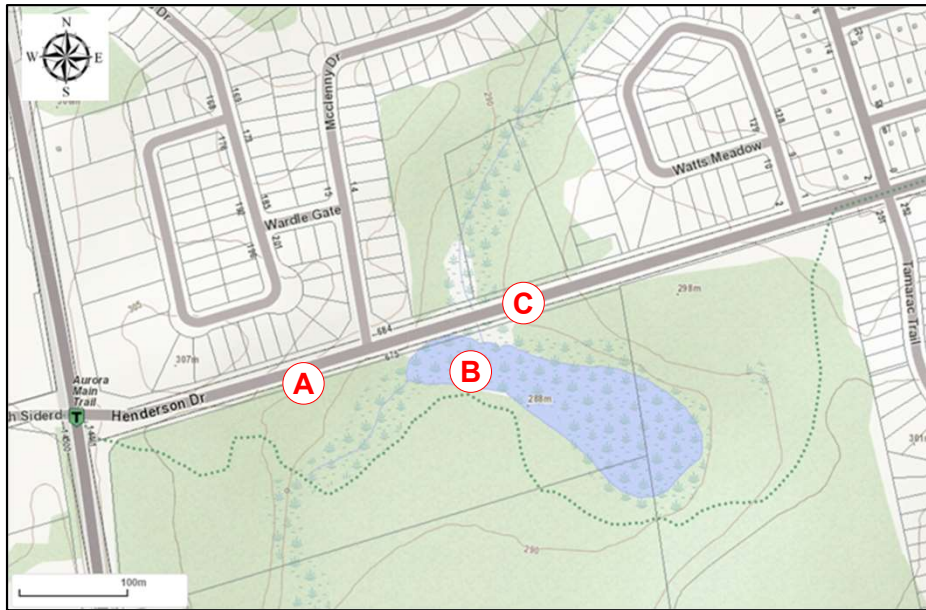

Wildlife Crossing Sign on Henderson Drive



Salamander Pond



Henderson Drive Looking West Towards McClenny Drive

EXISTING CONDITIONS

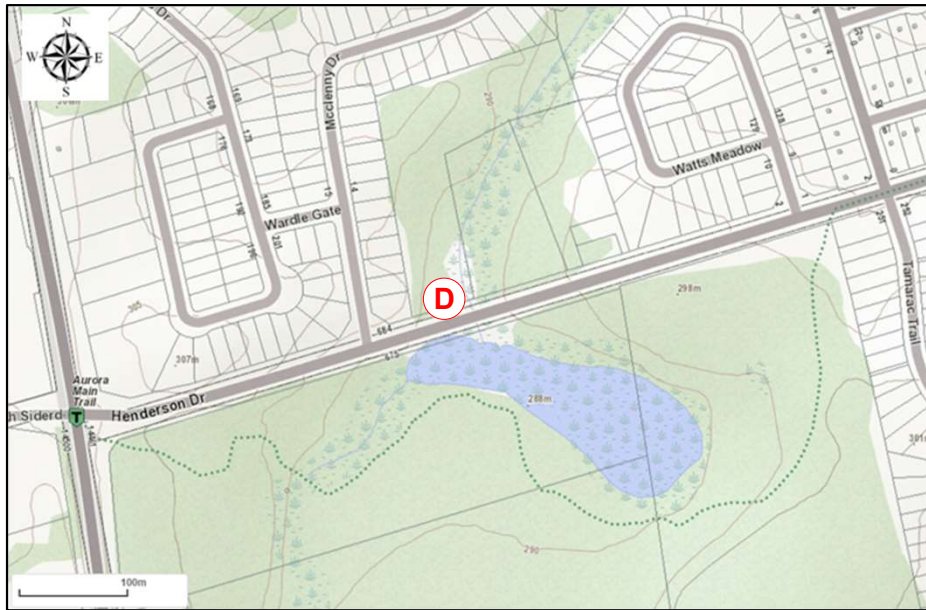

Failing Guard Rail on the North Side of Henderson Drive



Private Property North of Henderson Drive



Existing Culvert Outlet. Note Significant Loss of Conveyance Capacity Due to Sediment Accumulation

EXISTING CONDITIONS

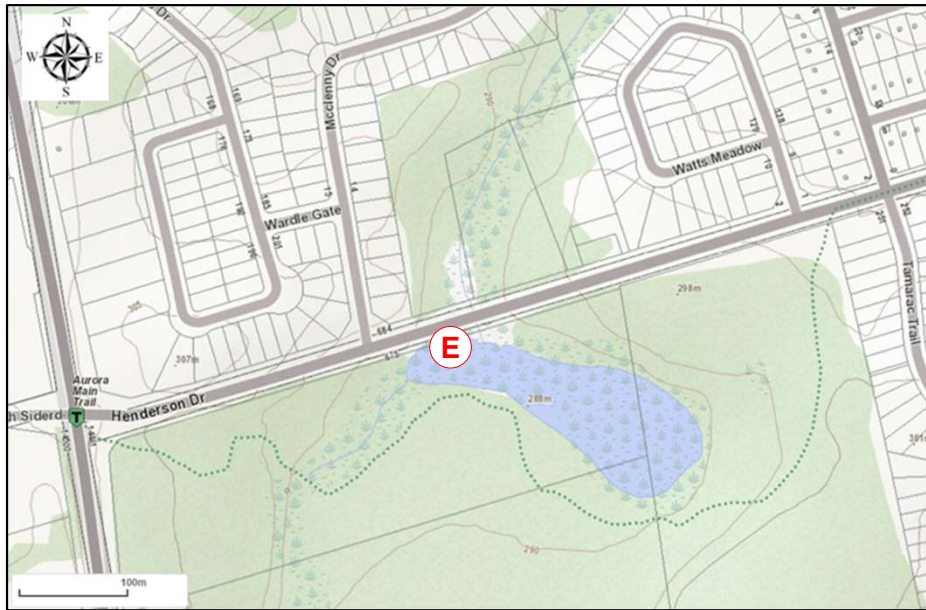

Existing Culvert Inlet Pipes and Headwall Structure



CSP Culvert Beneath Henderson Drive. Note Signs of Corrosion and Loss of Capacity Due to Sediment Accumulation



Salamander Pond Upstream of the Existing Culvert Inlet

TERRESTRIAL ECOLOGY

Ecological Land Classification (ELC) is a standard practice used to describe, identify, classify and map vegetation communities on the landscape. Community types found within the study area are shown in the map below:



AQUATIC ECOLOGY

- The study area provides habitat to a variety of fish, reptile and anuran species.
- The site specific aquatic habitat conditions are representative of a watercourse with wetland drainage features, with little definition or clear banks and few contributing crossovers or morphological features.
- The existing CSP culvert is undersized and partially blocked. Under these conditions, it acts as a barrier to fish and wildlife passage.



WILDLIFE CROSSING OBSERVATIONS

Turtle observation data collected between 2018 and 2020 documented the following:

- 58 painted turtle observations
- 65 snapping turtle observations

It has been observed that turtles regularly cross the road for nesting purposes. A safe wildlife passage crossing is therefore needed to mitigate roadside fatalities.



Turtle Nesting on North Side of Henderson Drive



Turtle Nesting at Curb on the South Side of Henderson Drive

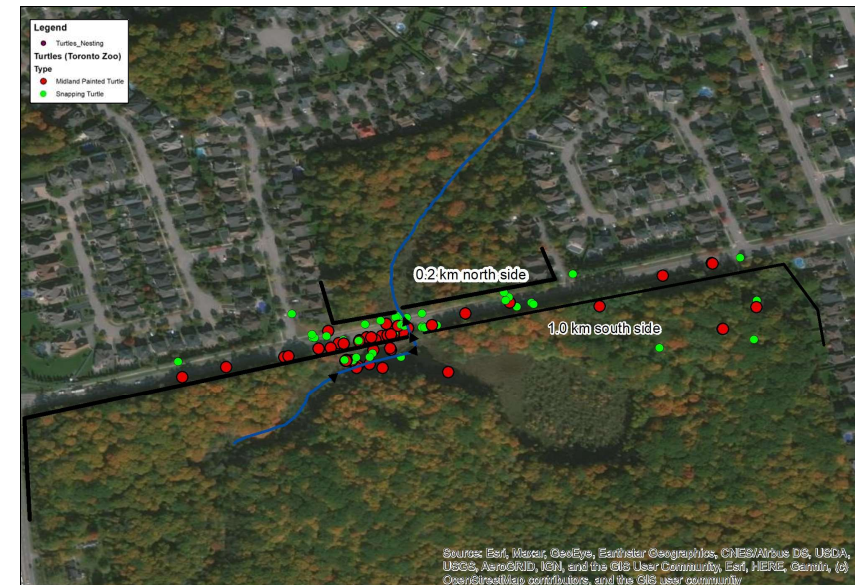

Turtle Observation Data along Henderson Drive

HYDROLOGY AND HYDRAULICS

The study undertaken assessed the Hydrology and Hydraulics of the study area in order to understand how water flows through the project site, the forces it exerts under normal and extreme conditions, and the extent of flooding, so as not to worsen or impact flood levels.

The modelled limits of the Regional floodplain are shown below, highlighting that the proposed design will not increase the Regional flood line extents.



OWNERSHIP AND ACCESS



Henderson Drive Wildlife Eco-Passage

The Henderson Drive Right-of-Way and Salamander Pond are Town owned property. The forested area to the north of the project study area is privately owned. Construction works will be limited to publicly owned lands.

The site will be accessed from Henderson Drive. A temporary road closure will be required to remove the existing CSP culverts and install the new wildlife eco-passage conduit.

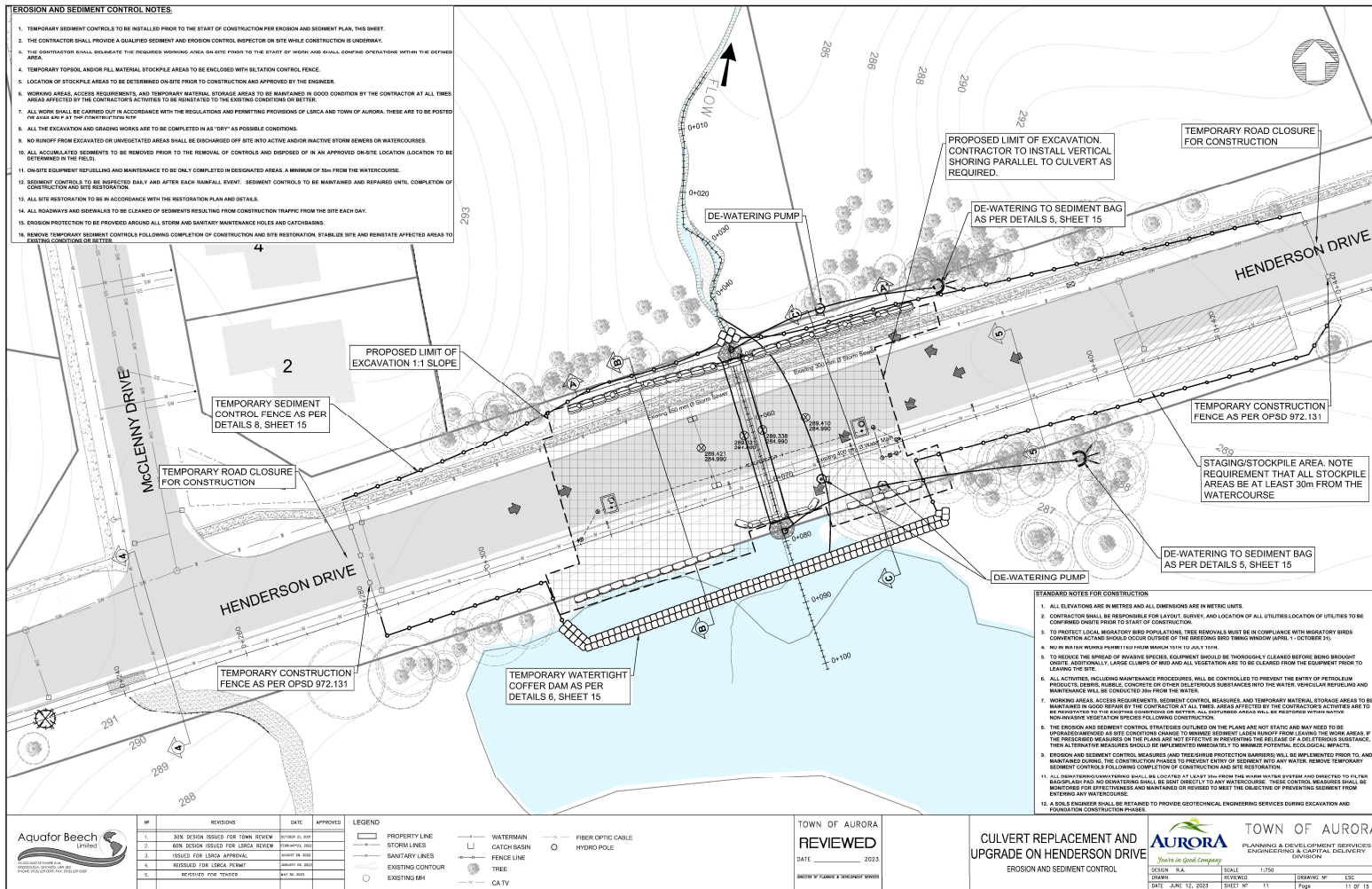

DETAILED DESIGN – WILDLIFE ECO-PASSAGE



Henderson Drive Wildlife Eco-Passage

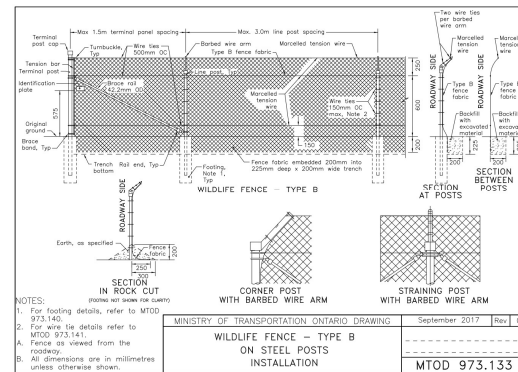
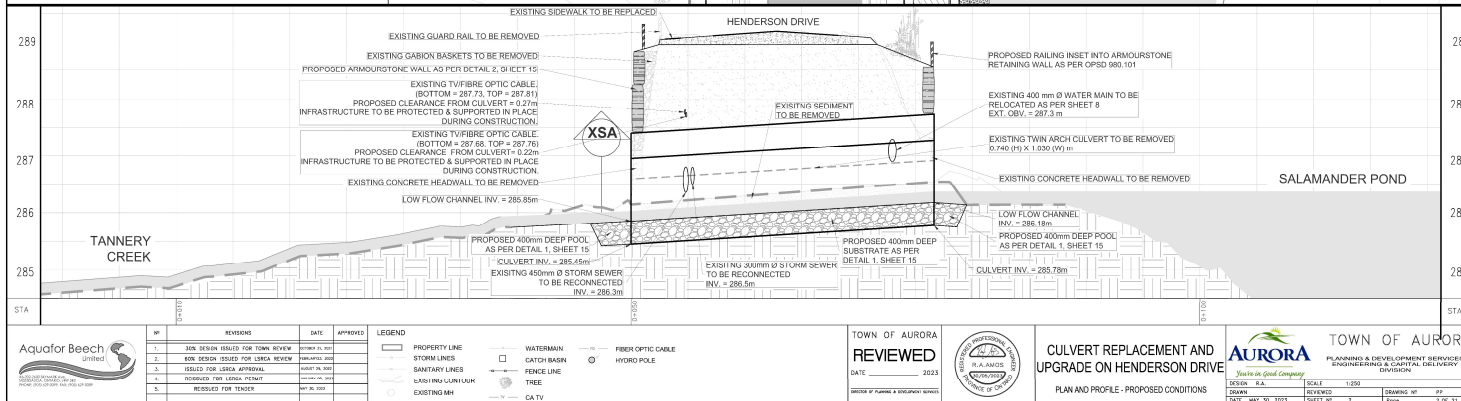
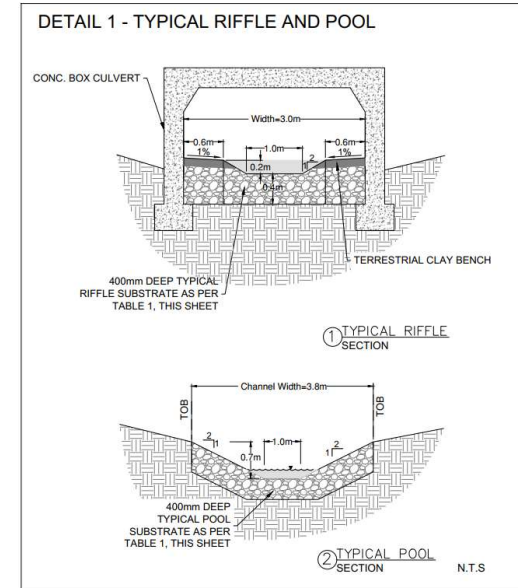
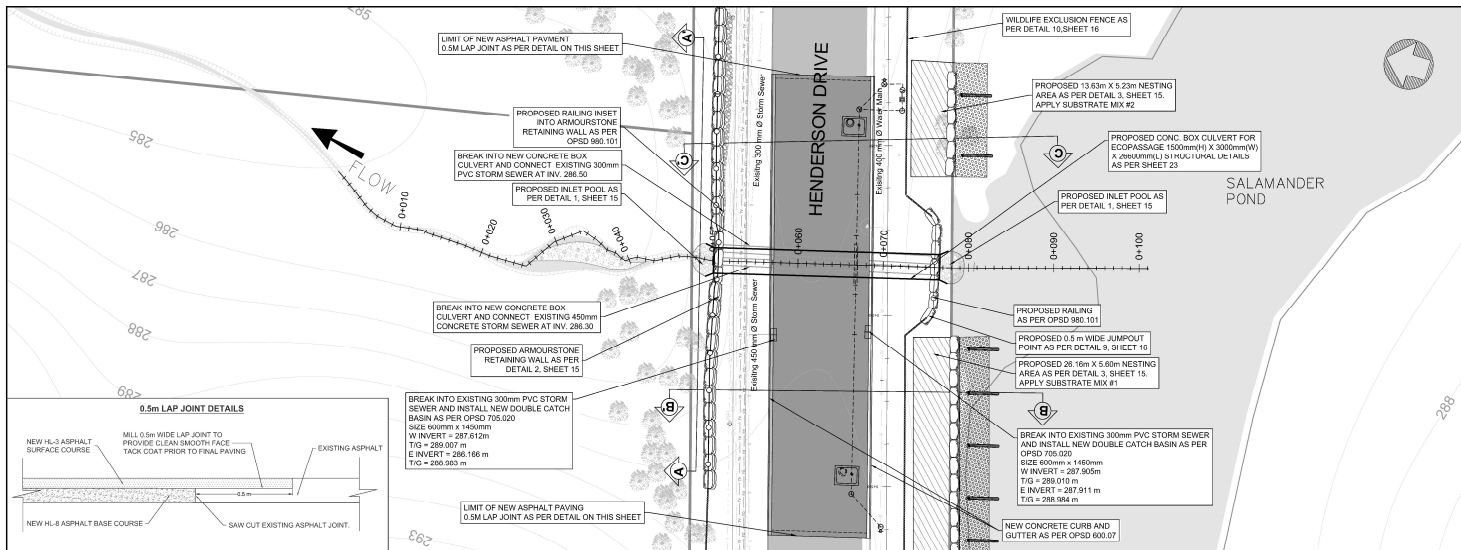

- Replacement of the existing twin CSP culvert with a new single barrel concrete box culvert
- The new culvert will be enlarged and will be designed with a defined low flow channel and terrestrial clay benches to facilitate wildlife passage
- Installation of wildlife exclusion fencing to prevent wildlife from bypassing the planned culvert passage
- Construction of turtle nesting areas and basking logs to enhance ecological habitat conditions

DETAILED DESIGN – OTHER COMPONENTS



Henderson Drive Wildlife Eco-Passage

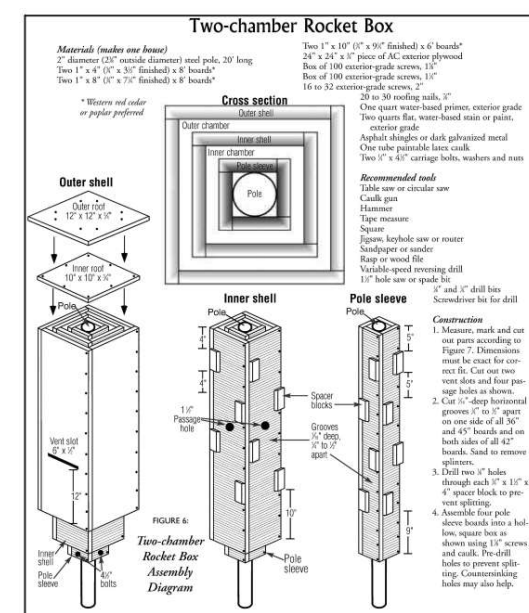
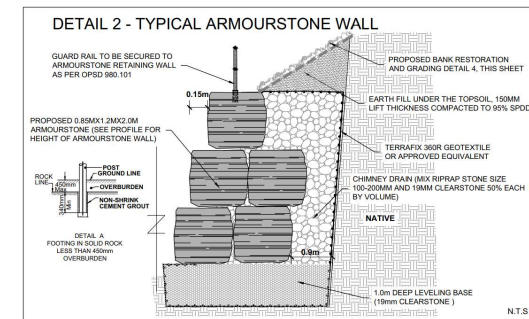
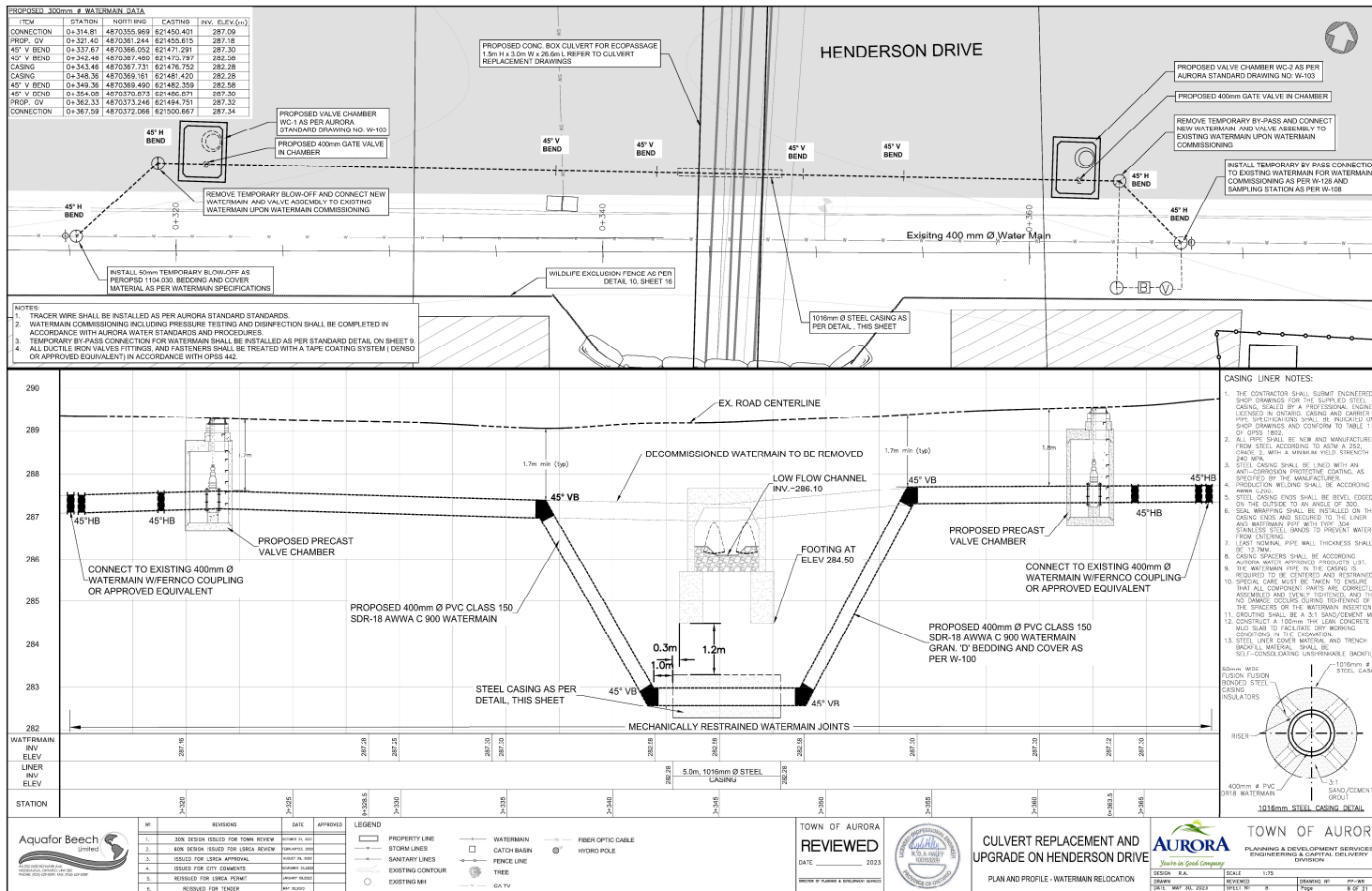

- Relocation of a 400 mm diameter watermain to facilitate the culvert replacement
- Replacement of the failing guard rail and gabion basket retaining wall with a new Armourstone wall.
- Construction of engineered scour pools at the culvert inlet and outlets to mitigate erosion
- Installation of bat rocket boxes to provide compensation for the removal of bat habitat trees

DETAILED DESIGN – WILDLIFE ECO-PASSAGE



Example of Wildlife Fencing Installation with Steel Posts



Example of a Riverstone Nesting Mound beside a Pond Feature



Example of An Enlarged Culvert Designed to Facilitate Wildlife Passage with Terrestrial Clay Benches - City of Burlington



Example of Bat Rocket Box Installation – City of Toronto

DETAILED DESIGN – TREE REMOVAL PLAN



Henderson Drive Wildlife Eco-Passage

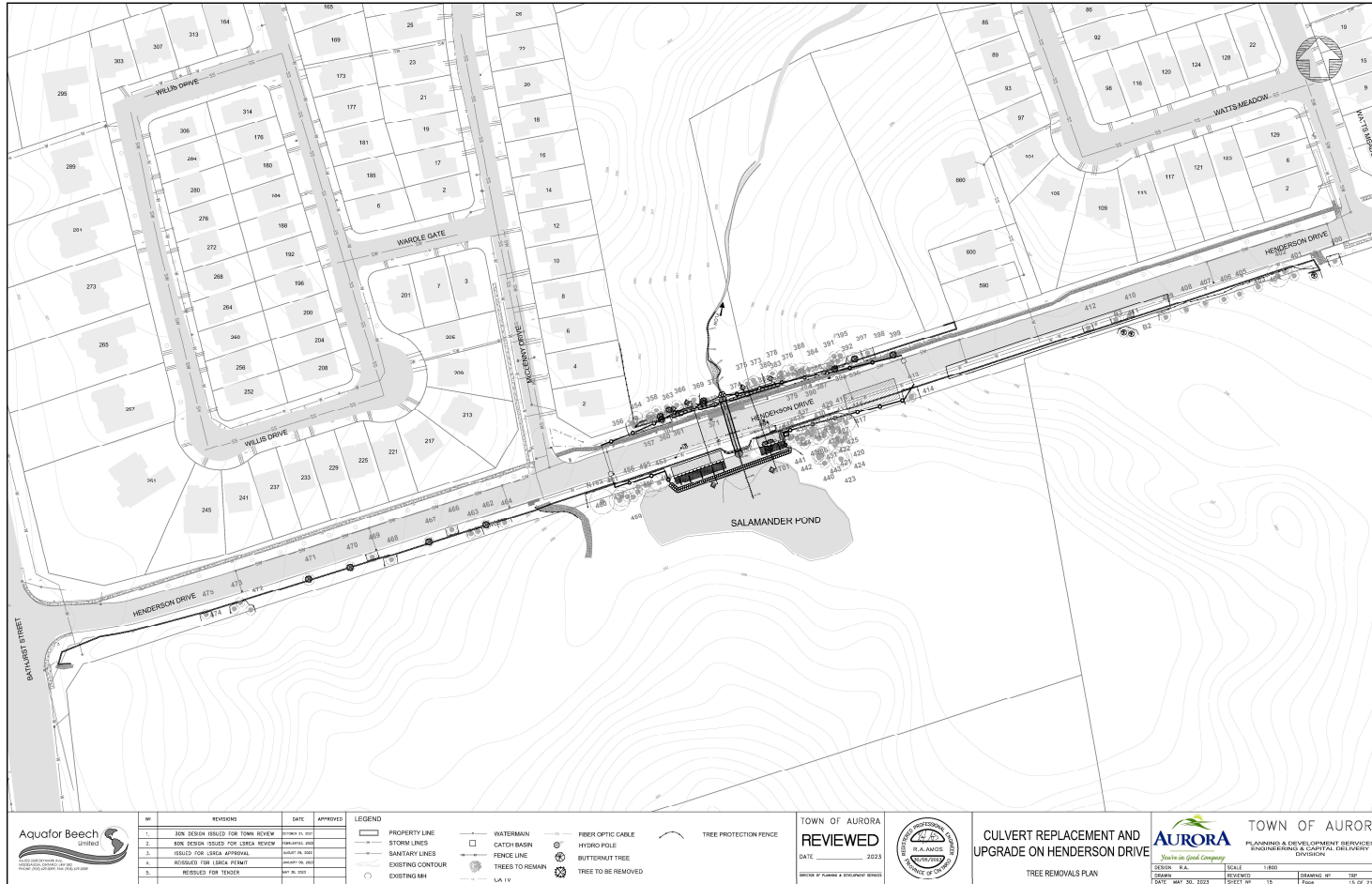

126 Trees Inventoried

15 planned tree removals

- x4 Sugar Maple
- x4 Manitoba Maple
- x3 Crack Willow
- x2 Trembling Aspen
- x1 Apple Tree
- x1 White Poplar

28 Additional Trees to be Impacted

	NO.	REVISIONS	DATE	APPROVED	LEGEND PROPERTY LINE STORM LINES SANITARY LINES EXISTING CONTOUR EXISTING MH WATERMAIN CATCH BASIN FENCE LINE TREES TO REMAIN LA 1V FIBER OPTIC CABLE HYDRO POLE BUTTERNUT TREE TREE TO BE REMOVED TREE PROTECTION FENCE	TOWN OF AURORA REVIEWED DATE: 2023		CULVERT REPLACEMENT AND UPGRADE ON HENDERSON DRIVE TREE REMOVALS PLAN	TOWN OF AURORA PLANNING & DEVELOPMENT SERVICES ENGINEERING & SURVEY DIVISION
	1.	30% DESIGN SUBMITTED FOR TOWN REVIEW	2023-01-10						
	2.	60% DESIGN ISSUED FOR LSICA REVIEW	2023-01-10						
	3.	DESIGNED FOR LSICA APPROVAL	2023-01-10						
	4.	DESIGNED FOR LSICA PERMIT	2023-01-10						
5.	REVISED FOR TENDERS	2023-01-10							
SCALE: 1:400 SHEET NO. 15 DRAWING NO. 18P DATE: 2023-01-30, 2023-02-01 PAGE: 15 OF 21									

NEXT STEPS

PUBLIC CONSULTATION – SEPTEMBER 2023

- Any questions or concerns can be directed to Garry Anggawinata at the Town of Aurora.
- The project team will compile and review feedback, and will confirm or adapt the detailed design accordingly.

UTILITY RELOCATIONS – SEPTEMBER 2023

- Minor hydro pole relocations to be completed in advance of construction

CONSTRUCTION - 2023

- Construction currently planned to start Q4 2023.

TO PROVIDE COMMENT, OR TO BE ADDED TO THE STUDY STAKEHOLDER LIST, PLEASE CONTACT:

Mr. Garry Anggawinata, P.Eng.
Municipal Engineer
Town of Aurora
Planning & Development Services
100 John West Way, Box 1000
Aurora, Ontario L4G 6J1
Phone: 365.500.3117
E-mail: GAnggawinata@aurora.ca

Mr. Rob Amos, P. Eng.
Project Manager
Aquafor Beech Limited
2600 Skymark Ave., Suite 202,
Building 6, Mississauga, L4W 5B2
Phone: 905-629-0099 x 284
E-mail: amos.r@aquaforbeech.com

THANK YOU

**FOR PARTICIPATING IN THE HENDERSON DRIVE
WILDLIFE ECO-PASSAGE
PUBLIC INFORMATION CENTRE**

Notice Letters to be Sent out Prior to the Start of Construction